

PA711E9(Z) Data Sheet

52 pin PLCC socket/28 pin DIP 0.6" plug

Supported Device/Footprints

Using this adapter, the Motorola 68HC711E9 in either PLCC or CLCC package can be programmed on DIP programmers.

Device			Footprint	
Mfgr	Device	Package	Device	Plug
Motorola	68HC711E9	PLCC, CLCC	68HC711E9	28 pin DIP

Adapter Parts & Part Numbers

The following chart shows the various socket and board part numbers that make up these adapters.

Adapter	Socket	Top Board	Bottom Board
PA711E9	52-107	711E9	28-170
PA711E9Z	52-411	711E9Z	28-170

Adapter Dimensions

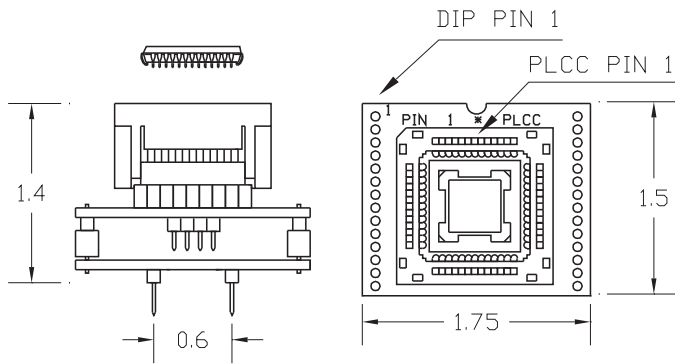

Press rim to open socket, Press device to close

PA711E9

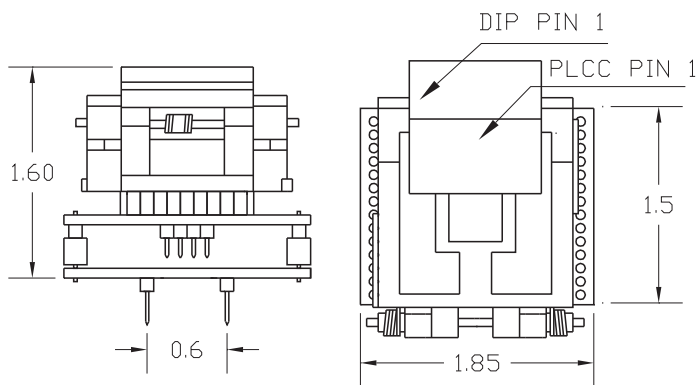

PA711E9Z

Adapter Construction

The adapter is made up of 3 sub-assemblies. They assemble via connectors making the adapter modular. This way the sub-assemblies can be replaced when they wear out.

When disassembling the adapter take care not to bend the pins. When reassembling the adapter note the pin 1 indicators to align the parts correctly.

Test Socket

PLCC Auto-Eject test socket:

Yamaichi Part #: IC120-0524-107

LSC Part #: 52-107

PLCC Lidded ZIF socket

Yamaichi Part #: IC51-0524-411

LSC Part #: 52-411

711E9(Z)

Accepts the test socket and performs the wiring shown in the Adapter Wiring section.

28-170

Connects the top board to the EPROM programmer.



Adapters-Plus Inc.

P.O. BOX 900
Tracy, Ca 95378
ph.209-839-0200
fax.209-839-0235
email: sales@adapt-plus.com

PA711E9(Z) Data Sheet

Doc: 711E9.DOC

Rev 7/18/97

Page 1 of 2

Adapter Wiring

The following chart shows the connections from the PLCC device to the adapter's DIP plug.

DEVICE	SIGNAL	PLUG
1	GND	14
2	GND	14
3	GND	14
4	D6	18
5	NC	-
6	D7	19
7	GND	14
8	NC	-
9	A0	10
10	A1	9
11	A2	8
12	A3	7
13	A4	6
14	A5	5
15	A6	4
16	A7	3
17	GND	14
18	VPP	1
19	-CE	20
20	D0	11
21	D1	12
22	D2	13
23	D3	15
24	D4	16
25	D5	17
26	VCC	28
27	GND	14
28	NC	-
29	NC	-
30	NC	-
31	GND	14
32	GND	14
33	GND	14
34	GND	14
35	-OE	22
36	A14	27
37	A13	26
38	A12	2
39	A11	23
40	A10	21
41	A9	24
42	A8	25
43	GND	14
44	GND	14
45	GND	14
46	GND	14
47	GND	14
48	GND	14
49	GND	14
50	GND	14
51	GND	14
52	GND	14

EPROM Address Mapping

During normal operation the 12K bytes of EPROM in an 'E9 is at address D000 thru FFFF. In PROG MODE the same EPROM is accessed by the programmer at addresses 1000 thru 3FFF. Additionally PROG MODE addresses 0000 thru 0FFF of the 'E9 are not programmable (they always read as 00).

The value intended for address D000 will have to be programmed into address 1000 on the EPROM programmer. When installed and run the 'E9 will fetch that byte from address D000.

The executable/load address translation may be made at compile/assemble time or during programming. Some assemblers and linkers provide a PHASE command to generate HEX files where the EPROM address and executable addresses are not the same. Most programmers either allow the hex file to be loaded with an offset or the EPROM to be programmed from anywhere in the RAM. Either method will do.

In PROG MODE A14 is a Don't Care. The programmer will access the same EPROM location in the 'E9 at addresses 0000 and 4000 (1000 and 5000 are the same). To prevent this from being a problem, either load the HEX file twice at both addresses or limit the programming range.



Adapters-Plus Inc.

P.O. BOX 900
Tracy, Ca 95378
ph.209-839-0200
fax.209-839-0235
email: sales@adapt-plus.com

www.adapt-plus.com